

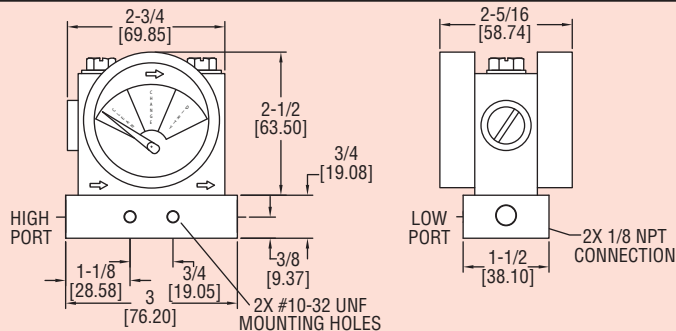

Series
PFG2

Process Filter Gage

Indicates Process Filter Status, In-Line or Bottom Connect Mounting



The Series PFG2 Process Filter Gage is designed for determining the state of an in-line filter. The differential pressure indicator determines the pressure drop on either side of a filter through its 1/8" female NPT pressure connections, and relates the value to one of three zones: clean (green), change (yellow), or dirty (red). The Series PFG2 is perfectly suited for filter applications, line loss, valve drop, and many other differential pressure applications where a simple indicator is needed. The direction of process flow is indicated on the dial, with the arrow pointing to the low pressure port. In order to change the high and low pressure connections, simply remove the indicator from the mounting base and rotate 180°. The PFG2 can be connected in-line through the side process connections, but can also be directly mounted through the outlet/inlet connections by removing the mounting block.

Model	Full Range	Green Zone	Yellow Zone	Red Zone
PFG2-02	0 to 5 psid	0 to 2.5 psid	2.5 to 3.75 psid	3.75 to 5 psid
PFG2-03	0 to 10 psid	0 to 5 psid	5 to 7.5 psid	7.5 to 10 psid
PFG2-06	0 to 25 psid	0 to 11 psid	11 to 18.5 psid	18.5 to 25 psid

SPECIFICATIONS

Service: Liquids/gases compatible with SS, GFN, and fluoropolymer.

Wetted Materials: Aluminum, SS, glass filled nylon, and fluoropolymer.

Accuracy: ±5% F.S.

Temperature Limit: 200°F (93°C).

Pressure Limit: 300 psig (20.7 bar).

Materials:

Body: Glass filled nylon;

Mounting Block: Aluminum;

Lens: Polyester;

Elastomers: Fluorocarbon.

Process Connection: 1/8" female NPT.

Mounting Orientation: Any orientation with 10-32 threaded holes 3/4" apart.

Weight: 9.6 oz (272.2 g).