

INDUSTRIAL AND PROCESS APPLICATIONS

MODEL : SDT01

Sanitary diaphragm pressure gauges are designed for use in Pharmaceutical, Biotechnology, Food, Beverages and Dairy applications.

They are constructed with hygienic Tri-clover sealed connections for measuring pressure in sanitary applications and are free of crevices and cavities to allow no areas for bacterial or archaeal growth.

FEATURES

- All Stainless steel construction
- 1.5" or 2" Tri-clover connection
- Whether proof to IP68 per IS/IEC 60529:2001
- Diaphragm material, SS316L
- Scale ranges upto 0...42 kg/cm²
- Available with liquid filled case for application with high dynamics pressure pulsations or vibrations

DESIGN

EN837-1

NOMINAL DIAL SIZE

NS 63, 100 & 150mm

ACCURACY (AS PER EN837-1)

1.6% of FSD

SCALE RANGES

0...2.5 kg/cm² to 0...40 kg/cm² (single range)
 0...2.1 kg/cm² / 30psi to 0...42 kg/cm² / 600psi (dual range)
 -1...3 kg/cm² to -1...24 kg/cm² (compound range)
 or other equivalent units of pressure & vacuum

WORKING PRESSURE

Steady : 75% of FSD
 Fluctuating : 66% of FSD
 Short Time : FSD

OPERATING TEMPERATURE

Ambient : -40 to 60°C without liquid filling
 -20 to 60°C gauge with glycerine filling
 Medium : 80°C max.

TEMPERATURE EFFECT

When temperature of the pressure element deviates from reference temperature (+30°C) : Max. ±0.4% / 10K of true scale value

PRIMARY SENSING ELEMENT

Diaphragm, SS316



DIAPHRAGM HOUSING

SS316L

SEAL FLUID

Silicon oil

SECONDARY SENSING ELEMENT

Bourdon tube, SS316L

MOVEMENT

SS304

DIAL

Off-white aluminum with black & red lettering

POINTER

Black aluminum. Fixed pointer for NS 63mm
 Black aluminum. Zero-adjustment pointer for NS 100 & 150mm

CASE & BEZEL

SS304, Bayonet type

INGRESS PROTECTION

IP68 as per IS/IEC 60529:2001

PROCESS CONNECTION

Material : SS316L
 Size : 1", 1.5" & 2" Tri-clover connection

WINDOW

Toughened glass
Instrument glass

MOUNTING

NS 63mm

Back Direct Entry, Centric (80)

NS 100 & 150mm

Direct Bottom (20)

Back Eccentric Mount (30)

BOD (VENT PLUG)

Neoprene

DAMPENING LIQUID

Glycerine 99.7%

OPTIONAL EXTRA

- Mounting clamp & gasket
- Mounting adaptor
- Silicon oil filling (sealed fluid)
- Alarm contacts see model EOC Series

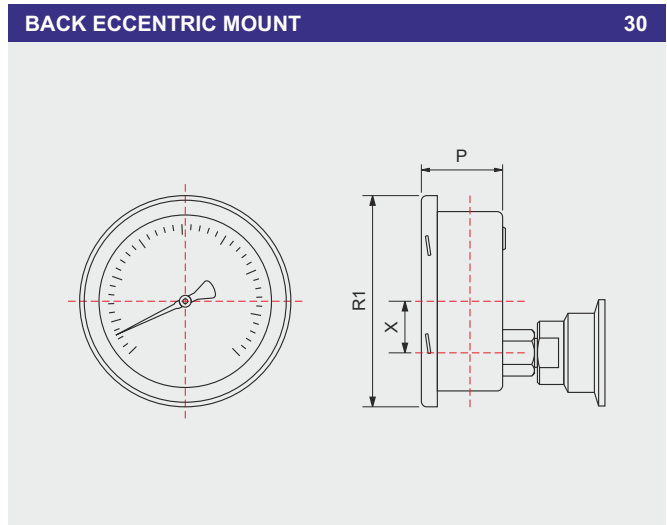
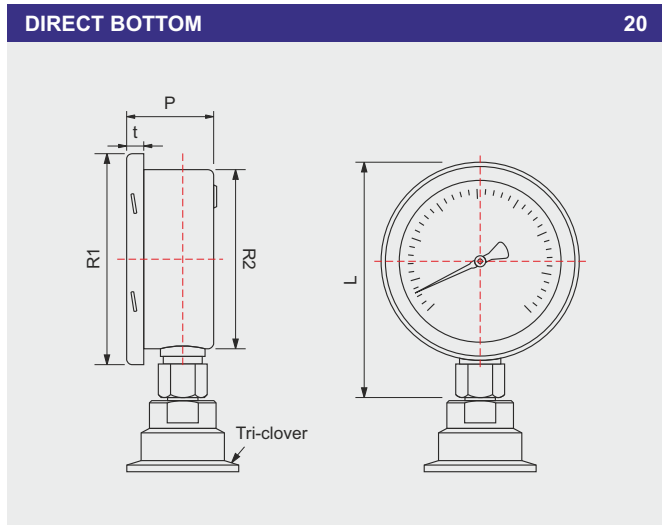

| DIAL SIZE | R1 | R2 | t | P | L | X |
|-----------|-----|-----|------|----|-----|----|
| 63 | 73 | 64 | 12.5 | 33 | 78 | 0 |
| 100 | 110 | 100 | 15 | 50 | 126 | 30 |

*All dimensions are in mm

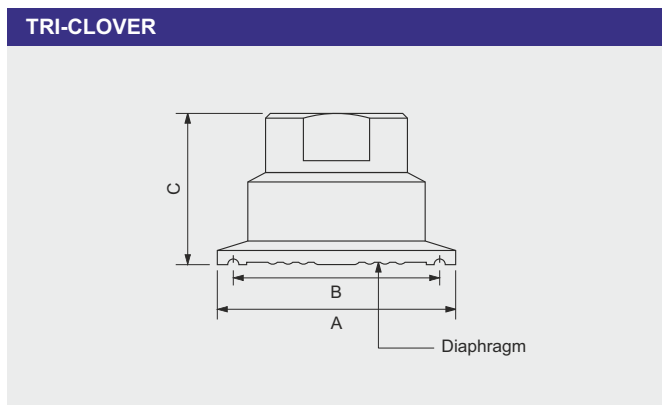

| SIZE (INCH) | A | B | C |
|-------------|------|-------|----|
| 1.5 | 50.4 | 43.64 | 32 |
| 2 | 63.5 | 56.34 | 38 |

*All dimensions are in mm

HOW TO ORDER

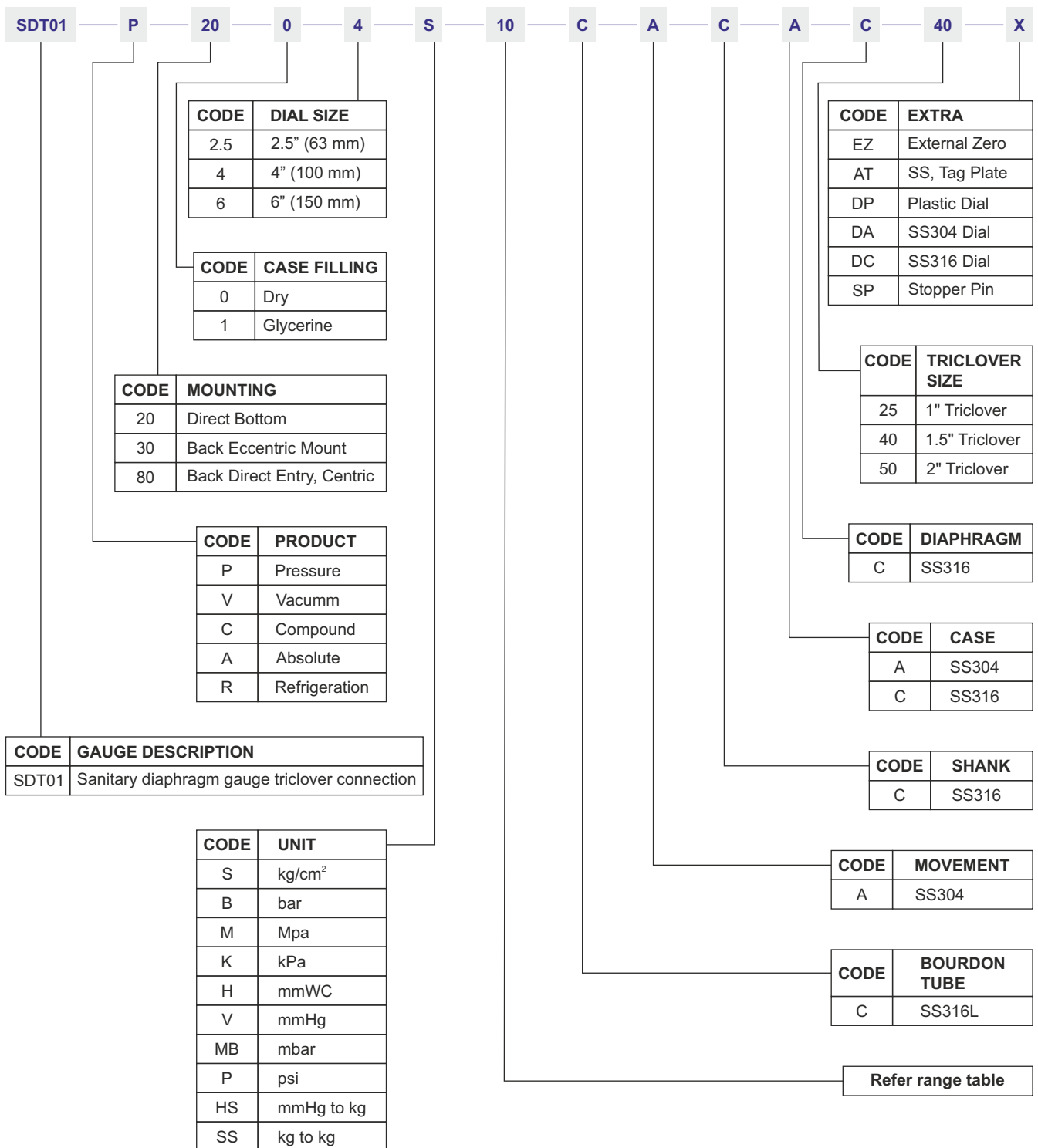

ACCESSORIES

| CODE | SANITARY GASKETS |
|------|-----------------------------------------|
| GF | Silicone, FDA Approved |
| GP | Silicone, FDA Approved & Phthalate Free |

| CODE | TRICLOVER FERRULE |
|-----------|-------------------------|
| TC25x21.5 | 1" Tri-clover Ferrule |
| TC40x21.5 | 1.5" Tri-clover Ferrule |
| TC50x21.5 | 2" Tri-clover Ferrule |

| CODE | CLAMP |
|------|------------|
| TC25 | 1" Clamp |
| TC40 | 1.5" Clamp |
| TC50 | 2" Clamp |