



- Universal input
- 0 / 1 / 2 / 3 / 4 setpoints
- Isolated 0/4~20 mA or 0-10 V DC retransmission output
- 24 V DC transmitter supply
- RS485 / MODBUS RTU
- 85~265 V AC SMPS
- ONOFF control

SPECIFICATIONS All specifications at ambient of 25 °C, unless specified otherwise

<p>INPUT</p> <p>Input group 1 Thermocouple RTD Voltage Current</p> <p>Input group 2 Thermocouple RTD Current</p> <p>Voltage</p> <p>Transmitter supply Range limits Accuracy Cold junction compensation Sensor break protection</p> <p>INDICATION</p> <p>Process variable</p> <p>Setpoint</p> <p>Status indication</p> <p>OUTPUTS</p> <p>No. of relays Relay contact type</p> <p>Relay contact rating SSR drive</p> <p>Current output</p> <p>Maximum load for current output</p> <p>Voltage output Load for voltage output</p> <p>COMMUNICATION</p> <p>Port Protocol Slave ID</p>	<p>B, E, J, K, N, R, S, T Pt100, 3-wire 0~50 mV 0~20 mA, 4~20 mA</p> <p>B, C, D, E, G, J, K, N, R, S, T Pt100, 3-wire, Cu53 0~20 mA, 4~20 mA, Square root 0~50 mV Through DIP selection following voltage inputs are available : 0~1 V, 0~5 V, 0~10 V, 0~10 mV, 0~100 mV, 0~200 mV 22 V nominal, 30 mA max See Table 1 See Table 1 Automatic User programmable</p> <p>Upper : 4 digit, 7 segment 0.3" (7.6 mm) red LED display Lower : 4 digit, 7 segment 0.3" (7.6 mm) green LED display LEDs for relay status</p> <p>0 / 1 / 2 / 3 / 4 NO-C-NC (RLY1, RLY2) NO-C (RLY3, RLY4) 5A / 230V AC, resistive 12 V DC drive signal for external SSR 4~20 mA / 0~20 mA / 20~4 mA / 20~0 mA isolated from input 500 ohms</p> <p>0~10 V / user specified >10 Kohms</p> <p>RS485 Modbus RTU User programmable (1~256)</p>	<p>PROGRAMMABLE PARAMETERS</p> <p>Setpoint Unit Resolution</p> <p>High scale Low scale Digital filter Hysteresis Bias (for process variable) Relay logic</p> <p>Alarm types</p> <p>Alarm acknowledge</p> <p>Setpoint lock Level lock Relay action</p> <p>OTHER</p> <p>Programming Dimensions (in mm) Mounting Panel cutout Supply voltage</p> <p>Power consumption Operating ambient temperature Relative humidity</p> <p>Full range (See Table 1) °C, °F, EU User selectable 0.01, 0.1 or 1 for linear input, 0.1 or 1 for temperature Full range (See Table 1) Full range (See Table 1) A (minimum) ~ F (maximum) 0~25% span -50 to 50% of range limit a. Heat b. Cool c. Fullscale high alarm d. Full scale low alarm e. Deviation high alarm f. Deviation low alarm g. Inband alarm h. Outband alarm (e. to h. available for SP2, SP3, SP4 only) Self reset or latched and can be disabled at power on Front panel function used to reset relay in alarm condition ON, OFF ON, OFF Reverse / direct</p> <p>Through 3 tactile keys 48(W) x 96(H) x 115(D) Panel mount 44 (+0.8mm) x 92 mm a) 85~265 V AC, 50/60 Hz b) 20~35 V DC (optional) 4 watts maximum</p> <p>0~50 °C Below 90%, non condensing</p>
---	---	---

TABLE 1

SENSOR / INPUT	RANGE LIMITS (°C / EU)		RANGE IN WHICH ACCURACY IS SPECIFIED		TYPICAL ACCURACY AT 30 °C (°C / EU)	WORST CASE ACCURACY (°C / EU)
	LOW SCALE	HIGH SCALE	LOW SCALE	HIGH SCALE		
Input Group 1						
Pt - 6% Rh / Pt - 30% Rh (B)	400	1820	400	1820	± 3	± 5
Chromel / Constantan (E)	-270	850	0	850	± 1	± 3
Iron / Constantan (J)	-210	760	0	760	± 1	± 3
Chromel / Alumel (K)	-270	1372	-50	1200	± 1	± 3
Nicrosil / Nisil (N)	-270	1300	-50	1200	± 1	± 3
Pt / Pt - 13% Rh (R)	0	1760	400	1760	± 2	± 5
Pt / Pt - 10% Rh (S)	0	1760	400	1760	± 2	± 5
Copper / Constantan (T)	-270	400	-200	400	± 1	± 3
Pt100, 3-wire	-200	850	-200	600	± 0.3	± 1.0
Linear (0~50 mV, 0~20 mA, 4~20 mA)	-1999	9999	-1999	9999	± 5 EU	± 20 EU

Input Group 2

The following inputs are available in Input Group 2 in addition to inputs of Input Group 1.

Tungsten - 5% Rh / Tungsten - 26% Rh (C)	0	2320	0	2320	± 3	± 5
Tungsten - 3% Rh / Tungsten - 25% Rh (D)	0	2310	0	2310	± 3	± 5
Tungsten / Tungsten - 26% Rh (G)	0	2310	0	2310	± 3	± 5
Cu53	0	180	0	180	± 0.3	± 0.5
Linear (0~10 mV, 0~100 mV, 0~200 mV, 0~1 V, 0~5 V, 0~10 V)	-1999	9999	-1999	9999	± 5 EU	± 20 EU
Linear (4~20 mA) with square root	0	9999	0	9999	± 10 EU	± 40 EU

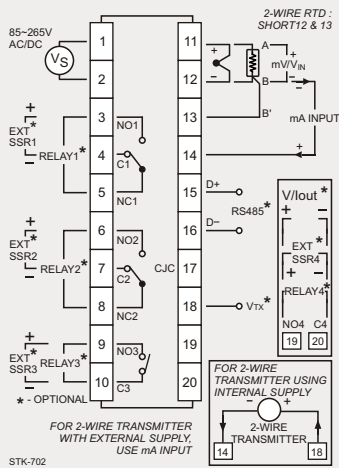
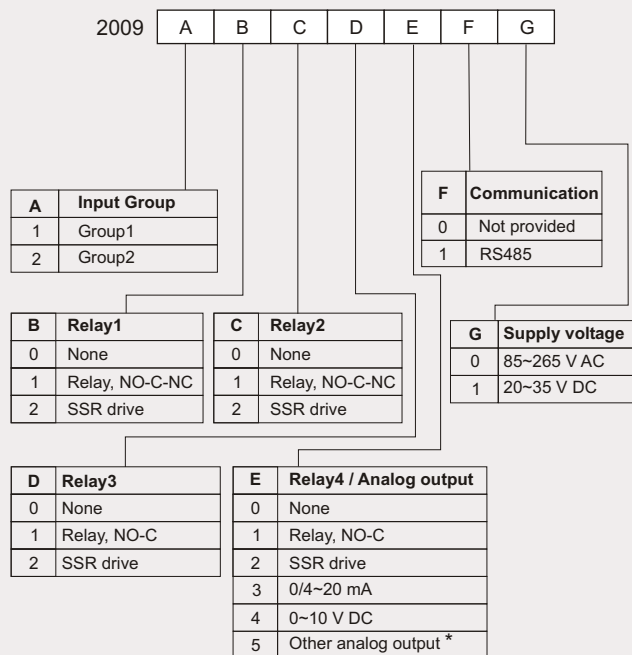
CONNECTION DIAGRAM

ORDERING INFORMATION

* Please specify