

AC/DC CURRENT/VOLTAGE TRANSDUCER

**DUAL 4-20 mA / 0-10 V DC OUTPUT
RS485/MODBUS RTU**

- Input : AC Volts, AC Amps, DC Volts, DC Amps
- Outputs : 2 x 0/4~20 mA, 0~1/5/10 V DC
- Input/supply/outputs mutually isolated
- Accuracy : Class 0.5, Class 0.2
- Supply : 18~42 V DC or 85~265 V AC
- Calibration and configuration through PC
- RS485/MODBUS RTU option
- 100 milliseconds fast response output option
- Slim 22.5 mm wide, Din-rail enclosure



AC/DC CURRENT/VOLTAGE TRANSDUCER

SPECIFICATIONS

All specifications at ambient of 25 °C unless specified otherwise

INPUTS			COMMUNICATION PORT		
Input type		Specify any one listed below	Port	RS485	
AC voltage		0~50 V AC, 0~500 V AC	Protocol	Modbus RTU	
Input resistance for voltage input		1000 K ohm	Slave ID	User programmable (1~255)	
AC current		0~1 A AC, 0~5 A AC	Baud rate	1500 to 115200 bps (user programmable)	
DC voltage		0~50 V DC, 0~1000 V DC	ISOLATION		
Input Resistance for voltage input		1000 K ohm	Mutual isolation between input, supply, output1 & output2	a) 1500 V AC RMS, 50 hz / 1 minute b) 250 V AC RMS, 50 hz, continuous	
DC current		0~1 A DC, 0~5 A DC	POWER SUPPLY		
		See also Input Range Selection -Table 1	Supply voltage	a) 18~42 V DC b) 85~265 V AC, 50/60 hz	
Sampling interval		60 milliseconds	ENCLOSURE		
ACCURACY			Material	Nylon	
Accuracy		See Table 1	Dimensions (in mm)	100(H) x 22.5(W) x 114(D)	
Temperature effect on accuracy		± 0.02% span / °C	Mounting	Snap on for 35 mm DIN rail to DIN 46277	
CALIBRATION			Connection, single/stranded wires	≤ 2.5 mm ² , AWG 14	
		ZERO and SPAN through PC using DCC501 USB-to-Serial Converter	TEMPERATURE, HUMIDITY		
RESPONSE TIME			Ambient, operation	0 to 60 °C	
Output response time		Standard : < 1 S Fast : <100 ms	Relative humidity	0 ~ 95%	
ANALOG OUTPUTS			PROGRAMMABLE PARAMETERS		
No. of outputs		1 or 2	Input Hi	Range maximum	
Output type			Input Lo	Range minimum	
Current		4~20 mA / user specified	Input overrange monitoring	Upscale, Downscale for each output	
Max output current		22mA	Digital filter	Provided (0~10)	
Load for current output		0~750Ω	Baud rate	1200 to 115200 bps	
Voltage		0~10 V DC / user specified	Resolution	1, 0.1, 0.01, 0.001	
Max output voltage		12 V			
Load for voltage output		> 10 kohms			
Non - standard		Please specify Note : For EACH output, one of the standard or a user specified output MUST be specified			

TABLE 1

Input Range Selection : The user can configure the instrument for any range by using the DCC501 USB-to-Serial Converter. Table 1 below gives the range adjustment limits

Order code 2384-A-B-C-D-E	Parameter	Range	Minimum Range	Maximum Range	Possible Ranges	Accuracy
2384-X-0-X-X-X	AC Voltage	0~500 V AC	0~50 V AC	0~500 V AC	0~50 V AC, 0~100 V AC, 0~300 V AC, 0~500 V AC	Class 0.5
2384-X-1-X-X-X	AC Ampere	0~5 A AC	0~1 A AC	0~5 A AC	0~1 A AC, 0~2 A AC, 0~5 A AC	Class 0.5
2384-X-2-X-X-X	AC Ampere	0~1 A AC	0~50 mA AC	0~1 A AC	0~50mA AC, 0~150mA AC, 0~250mA AC, 0~500mA AC, 0~1A AC	Class 0.5
2384-X-3-X-X-X	AC Voltage	0~50 V AC	0~5 V AC	0~50 V AC	0~5 V AC, 0~15 V AC, 0~30 V AC, 0~50 V AC	Class 0.5
2384-X-4-X-X-X	DC Voltage	0~1000 V DC	0~50 V DC	0~1000 V DC	0~50 V DC, 0~100 V DC, 0~200 V DC, 0~500 V DC, 0~1000 V DC	Class 0.2
2384-X-5-X-X-X	DC Voltage	0~50 V DC	0~1 V DC	0~50 V DC	0~1 V DC, 0~5 V DC, 0~15 V DC, 0~30 V DC, 0~50 V DC	Class 0.2
2384-X-6-X-X-X	DC Ampere	0~5 A DC	0~1 A DC	0~5 A DC	0~1 A DC, 0~2 A DC, 0~5 A DC	Class 0.2
2384-X-7-X-X-X	DC Ampere	0~1 A DC	0~50 mA DC	0~1 A DC	0~50mA DC, 0~150mA DC, 0~250mA DC, 0~500mA DC, 0~1A DC	Class 0.2

Example

The range required is 0 to 100 V DC. For this, the input range 0~1000 V DC can be specified. Order code for the same will be [2384-X-4-X-X-X]

AC/DC CURRENT/VOLTAGE TRANSDUCER

ELECTRICAL CONNECTIONS

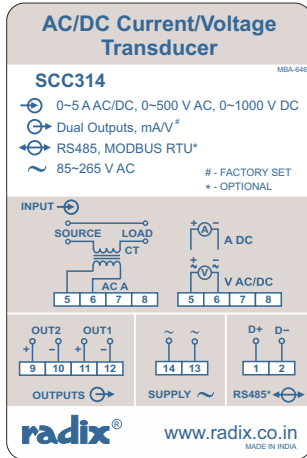

DIMENSIONS

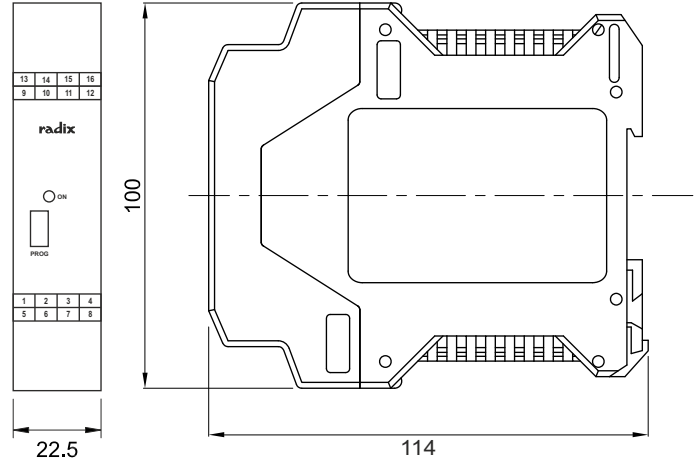

PC CONFIGURATOR FOR SCC314

DCC501/DCC505 Converters can be used to program the parameters and need to be purchased separately.

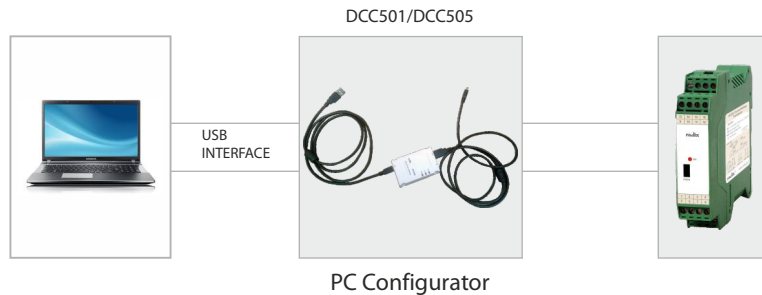

AC/DC CURRENT/VOLTAGE TRANSDUCER

ORDERING INFORMATION

Standard Order Codes

Product code	2384						
Supply voltage		0					18~42 V DC
Response time			0				<1 sec
Communication				0			RS232 USB to UART #1
				1			RS485 MODBUS output #2
Input					0		0~500 V AC
					1		0~5 A AC
					2		0~1 A AC
Output						0	4~20mA

#1 DCC501 to be used - See PC Configurators below

#2 DCC505 to be used - See PC Configurators below

EXAMPLE

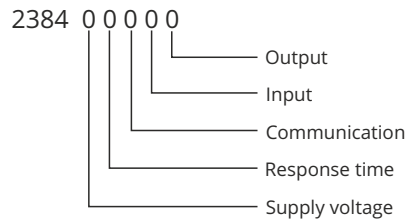

Special Order Codes

Input	See Table 1 for range adjustment limits 0~50 V AC 0~1000 V DC 0~50 V DC 0~5 A DC 0~1 A DC Other - Specify
Output	0~1 V DC 0~5 V DC 0~10 V DC Other - Specify
Supply voltage	85~265 V AC
Response time	<100m sec

PC Configurators

Parameter	Model	Order Code	Communication
USB-to-Serial Converter	DCC501	2555	RS232
USB-to-RS485 Converter - Isolated	DCC505	2588	RS485

ENQUIRIES

Instruments: sales@radix.co.in

Sensors: sensors@radix.co.in

Gauges: gauges@radix.co.in

Automation: automation@radix.co.in

Level: level@radix.co.in

RADIX ELECTROSYSTEMS PVT LTD
EL-135/136/137, Electronics Zone
TTC Indl. Area, MIDC, Mahape
Navi Mumbai - 400 710, India
+ 91 22 42537707 • sales@radix.co.in

radix®
www.radix.co.in