

COMPACT RTD SENSORS

- Pt100, 4 wire
- Class A accuracy as standard, Class AA optional
- -50...+200°C measuring range with cooling neck
- M12 connector with IP69K for electrical connection
- Variable insertion lengths from 30mm onwards
- Standard diameter 4mm.
- Extremely short response times
- Highly accurate even with short insertion lengths
- AISI 316L (1.4404) body and wetted parts
- Surface finish : Ra ≤ 0.51µm & ≤ 0.8µm for wetted & non-wetted surfaces respectively.
- Mating sanitary fittings optional
- Temperature range (ambient) : -40...+80°C
- Connecting cable : Optional, 5 meter long

APPLICATIONS

- Food & Beverage
- Laboratory & Medical
- Water & Waste water

ACCURACY OF Pt100 AS PER IEC 60751

Pt100	A (½B)	AA (⅓B)
0°C (100Ω)	±0.15°C/±0.06Ω	±0.1°C/±0.04Ω
100°C (138.5Ω)	±0.35°C/±0.13Ω	±0.27°C/±0.1Ω

HOW TO ORDER

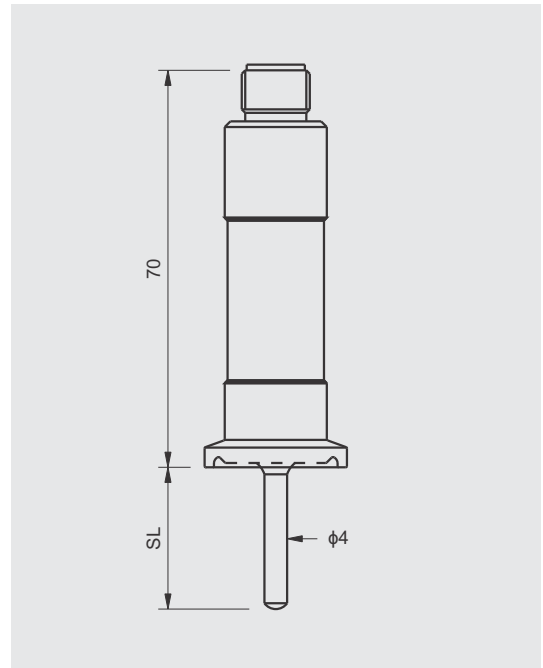
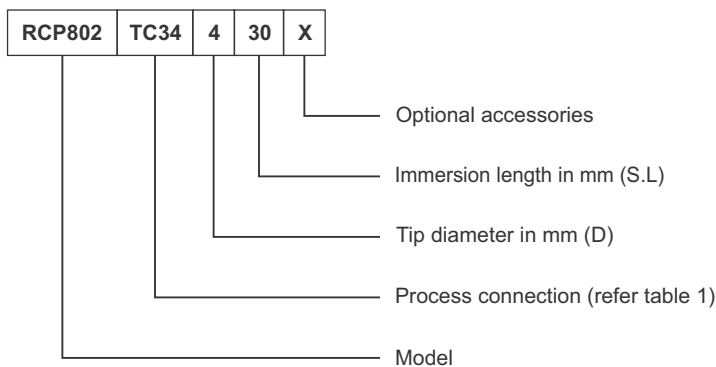

ELECTRICAL CONNECTION

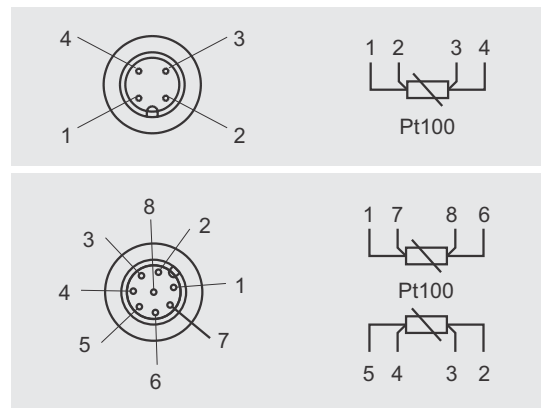

RESPONSE TIME

Tip Dia.	Imm. Length	T _{0.5}	T _{0.9}
4 mm	30 mm	2 s	4 s

T_{0.5} and T_{0.9} shows the response times at 50% and 90% of the step change. This data is measured by immersing the sensing bulb from ambient temperature to boiling water flowing at 0.4 m/sec. The result may vary according to the measuring environment and condition.

TABLE NO. 1

Size	Std φ	Min. Length
TC 34	4	30
TC 25	4	30